

# Product Manual

CELLEX 2023

# Product Catalog

## STG series



Base	DE30MLA
Host	DE30MA
Cable	LCS087-1C/M/FM/L
Recoiler	DE30RA

P12~14



Base	DE30MSA-1
Host	DE30MA-1
Cable	LCS087-1C/M/FM/L
Recoiler	DE30RB

P12~14



Base	DE30MSA
Host	DE30MA
Cable	LCS087-1C/M/FM/L
Recoiler	DE30RB
Arms	PJ040

P12~14



Base	DE30MSA
Host	DE30MA-3
Cable	LCS087-1C/M/FM/L
Recoiler	DE30RB

P15~17



Base	DE30MSA
Host	DE30MA-4
Cable	LCS087-1C/M/FM/L
Recoiler	DE30RB

P15~17

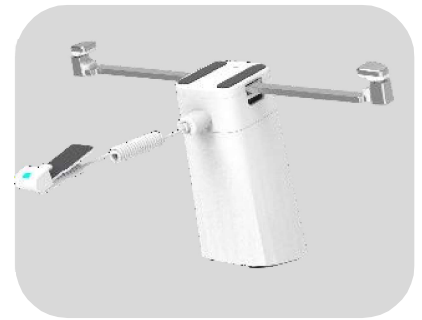

Base	DE30MSA
Host	DE30MA-2
Cable	LCS087-1C/M/FM/L
Recoiler	DE30RB

P18~20

# Product Catalog

## STG series

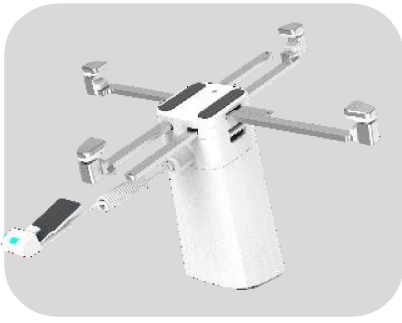

Base	DE30MSA
Host	DE30MA
Cable	LCS087-1C/M/FM/L
Recoiler	DE30RB
Arms	PJ041

P18~20

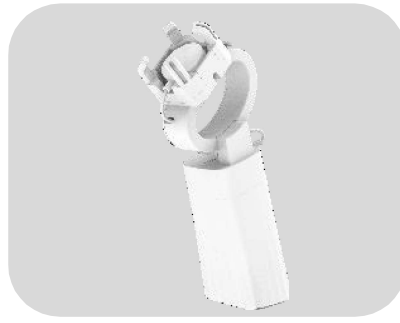

Base	DE30WLA
Host	DE30WA
Recoiler	DE30RA
Recoiler	DE30RB

P21~23

---

# Product Catalog

## STGpro series

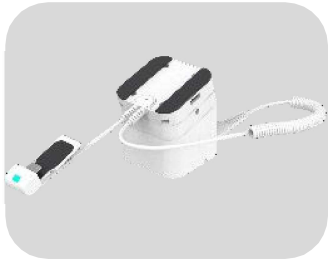

Frame	DE31MA
Host	DE31MLA
Cable	LCS356C/M/FM/L

P27~29

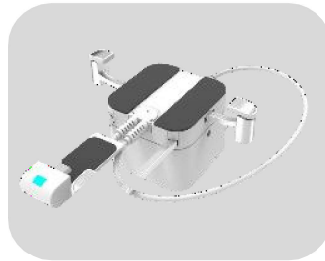

Frame	PJ018A/F
Host	DE31MLA
Cable	LCS-SW-002-SAC/M/FM/L-1

P27~29

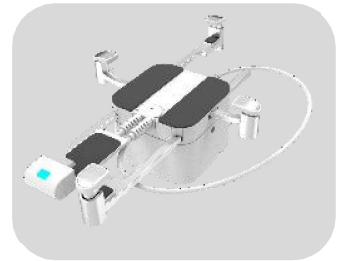

Frame	PJ018C/E
Host	DE31MSA
Cable	LCS-SW-002-SAC/M/FM/L-1

P27~29

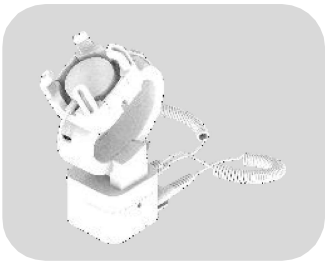

Frame	DE31WA
Host	DE31MLA
Cable	LS235-10

P30~32

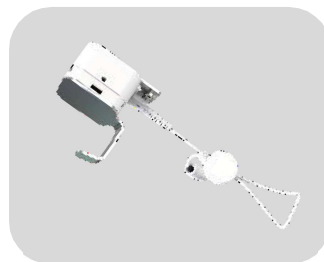

Frame	DE31EB
Host	DE31ELB
Cable	LS235-6

P36~38



Frame	DE31EA
Host	DE31ELA
Cable	LS235-6

P36~38

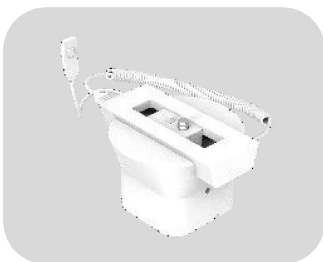

Frame	DE31CA
Host	DE31CLA
Cable	LCS415C-4 LS407-5

P39~41



Frame	DE31TA
Host	DE31TLA
Cable	LS235-11

P42~44



Frame	DE31TB
Host	DE31TLA
Cable	LS235-11

P42~44



# Product Catalog

## LTG series



Frame	DE40MA
Host	DE40MLA
Cable	LCS087-1C/M/FM/L
Recoiler	DE40RA

P51~53

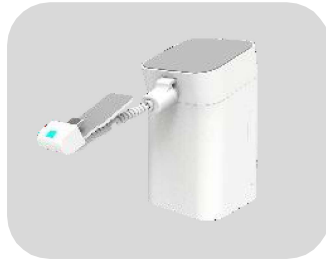

Frame	DE40MB
Host	DE40MLB
Cable	LCS087-1C/M/FM/L

P54~56



Frame	DE40WA
Host	DE40WLA
Recoiler	DE40RB

P57~59



Frame	DE40CA
Host	DE40CLA
Recoiler	DE40RE

P60~62



Frame	DE40TA
Host	DE40TLA
Recoiler	DE40RF

P66~68



Frame	DE40TB
Host	DE40TLB
Recoiler	DE40RF

P66~68



Frame	DE40EB
Host	DE40ELA
Recoiler	DE40RD

P63~65



Frame	DE40EC
Host	DE40ELC
Recoiler	DE40RD

P66~68

# Product Catalog

## LTGpro series

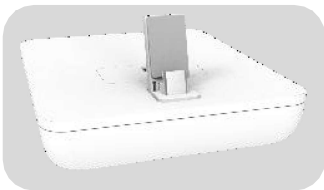

Frame	DE41MA
Host	DE41MLA
Recoiler	DE41RA

P74~76

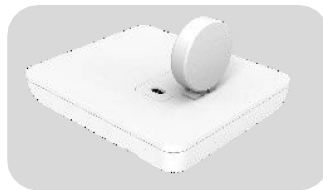

Frame	DE41WA
Host	DE41WLA
Recoiler	DE41RB

P77~79



Frame	FE41WA
Host	FE41WLA
Recoiler	DE41RB*2

P80~82

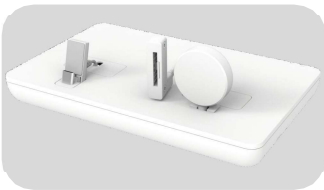

Frame	HE41WA
Host	HE41WLA
Recoiler	DE41RA+DE41RB

P83~85

---

# Product Catalog

## MP series



Frame	DE20MA
Host	FA409/809-DW
Cable	ZD007C

P90~91

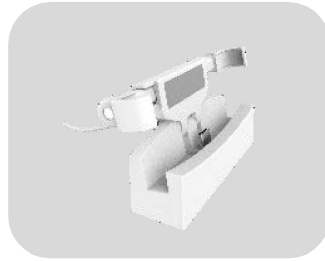

Frame	DE20MA
Host	FA409/809-DW
Cable	ZD027

P90~91



Frame	DE20WA
Host	FA409/809-DW
Cable	LS235-11

P90~91



Frame	DE20EA
Host	FA409/809-DW
Cable	LS235-9

P90~91

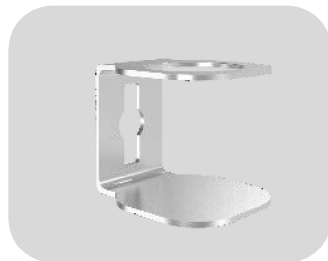

Frame	DE20TA
Host	FA409/809-DW
Cable	LS235-12

P90~91



FA409-DW



FA809-DW

P90~91

# Product Catalog

## SA series



Host	SK-E
------	------

P93~98



Host	L100
------	------

P93~98



Host	DH36PLA
Cable	LCS605C

P93~98



Host	DH36PSB
Cable	LCS605AC

P93~98



Host	DH36PSB
Cable	LCS605C+SH36PD

P93~98



Host	SH36MLA
Cable	LCS381C*2+LS009C*2

P93~98



Host	SH36MLA
Cable	LS288+LS289

P93~98



Host	SH36MSA
Cable	LS287A*2

P93~98



Host	SH36PLA
Cable	LCS607C

P93~98



Host	SH36PSA
Cable	LCS607AC

P93~98

**STG** mobile phone series





The new generation of internal recoiler display protection and anti-theft device, continuing the "simple and easy to use" design style, perfectly display the phone/tablet at a 75° Angle, with high security password management system, modular design, rapid disassembly and so on, providing a full range of display anti - theft services for merchandise.

## Features

- Stylish but Streamlined Design;
- Internal secured recoiler: cable with 32" pull length,Simplified aftersales enabled;
- Multiple security level choices: Standard, Enhanced or High protection;
- Enhanced steel cable with shear resistance 20kgf;
- Alarm-on-merchandise with 90 dB alarm;
- Quick release sensor with Eastops anti theft screwdriver;
- 360 degree lockdown for added security;
- Optional split type steel security arms (2 or 4);
- USB-A power interface with contact charging pins (5V, 2A)



Standard security  
3M adhesive fixed  
phone/tablet



Enhanced security  
slip silicone+2-way  
arms fixed phone/tablet



High security  
slip silicone+4-way  
arms fixed phone/tablet



standard cable  
(diameter 3.1 and length 80cm)



advanced cable  
(diameter 3.5 and length 80cm)



e-Tops

## Structure function

### 1 Type of charging security cable

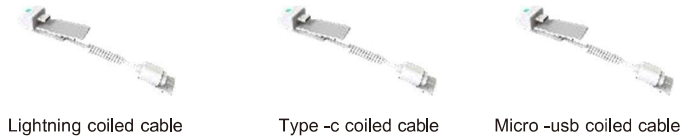

Lightning coiled cable

Type -c coiled cable

Micro -usb coiled cable

### 3 Installation way with desktop



using 3M adhesive



using metal fixing plate

### 2 Components

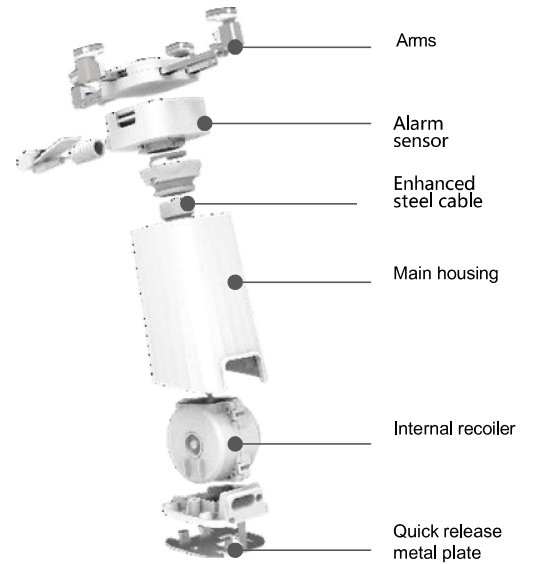

## Product dimension

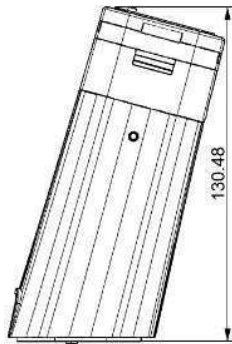

Left view

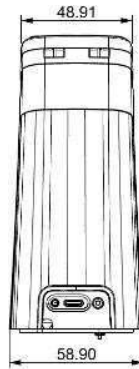

Back view

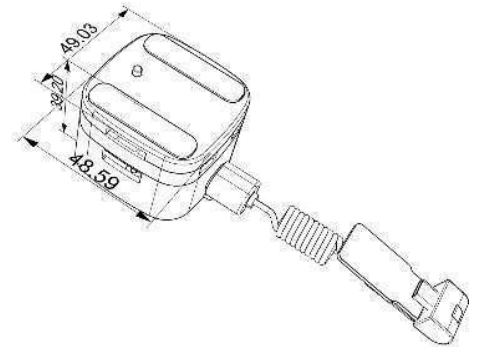

Protection sensor

## Clamp protection range

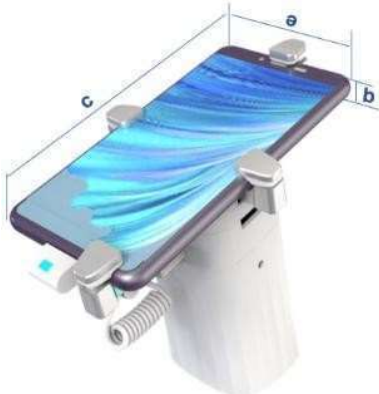

### The width and thickness range of clamp protection

Unit(mm)	Code	Width a		Thickness b
Two-way protection Range	DE30MA-1	57≤a≤90		6≤b≤11
	DE30MA-2	140≤a≤245		6≤b≤11
Four-way protection Range	Code	Width a	Length c	Thickness b
	PJ040	57≤a≤90	110≤c≤190	6≤b≤11
	PJ041	110≤a≤190	140≤c≤245	6≤b≤11

**STG** fold phone series



The new generation of internal recoiler display protection and anti-theft device, continuing the "simple and easy to use" design style, perfectly display the fold phone at a 75° Angle, with high security password management system, modular design, rapid disassembly and so on, providing a full range of display anti - theft services for merchandise.

## Features

- Stylish but Streamlined Design;
- Internal secured recoiler: cable with 32" pull length, Simplified aftersales enabled;
- Multiple security level choices: Standard, Enhanced or High protection;
- Enhanced steel cable with shear resistance 20kgf;
- Alarm-on-merchandise with 90 dB alarm;
- Quick release sensor with Eastops anti theft screwdriver;
- 360 degree lockdown for added security;
- Optional split type steel security arms ( 2 );
- USB-A power interface with contact charging pins (5V, 2A)



Enhanced security  
3M adhesive fixed  
Up & Down fold phone



Enhanced security  
3M adhesive fixed  
Left & Right fold phone



e-Tops

## Structure function

### 1 Type of charging security cable

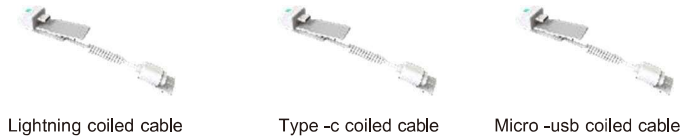

Lightning coiled cable

Type -c coiled cable

Micro -usb coiled cable

### 3 Installation way with desktop

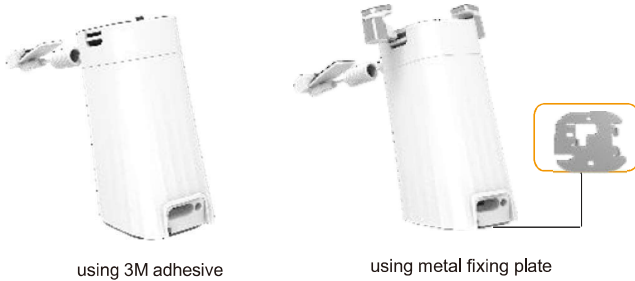

using 3M adhesive

using metal fixing plate

### 2 Components

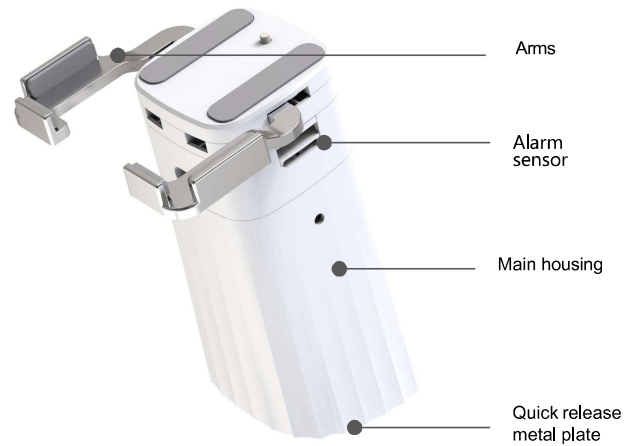

Arms

Alarm sensor

Main housing

Quick release metal plate

## Product dimension

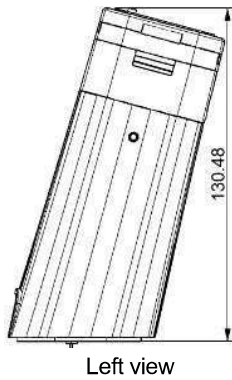

Left view

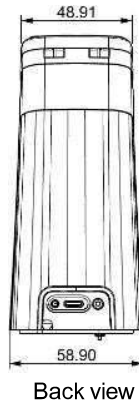

Back view

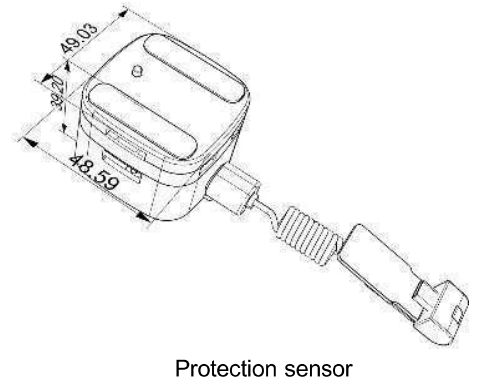

Protection sensor

## Clamp protection range



### The width and thickness range of clamp protection

Unit(mm)	Code	Width a		Thickness b
Two-way protection Range	DE30MA-1	57≤a≤90		6≤b≤11
	DE30MA-2	140≤a≤245		6≤b≤11
Four-way protection Range	Code	Width a	Length c	Thickness b
	PJ040	57≤a≤90	110≤c≤190	6≤b≤11
	PJ041	110≤a≤190	140≤c≤245	6≤b≤11



**STG** Tabletseries



The new generation of internal recoiler display protection and anti-theft device, continuing the "simple and easy to use" design style, perfectly display the phone/tablet at a 75° Angle, with high security password management system, modular design, rapid disassembly and so on, providing a full range of display anti - theft services for merchandise.

## Features

- Stylish but Streamlined Design;
- Internal secured recoiler: cable with 32" pull length, Simplified aftersales enabled;
- Multiple security level choices: Standard, Enhanced or High protection;
- Enhanced steel cable with shear resistance 20kgf;
- Alarm-on-merchandise with 90 dB alarm;
- Quick release sensor with Eastops anti theft screwdriver;
- 360 degree lockdown for added security;
- Optional split type steel security arms (2 or 4);
- USB-A power interface with contact charging pins (5V, 2A)



Standard security  
3M adhesive fixed  
phone/tablet



Enhanced security  
slip silicone+2-way  
arms fixed phone/tablet



High security  
slip silicone+4-way  
arms fixed phone/tablet



standard cable  
(diameter 3.1 and length 80cm)



advanced cable  
(diameter 3.5 and length 80cm)



e-Tops

## Structure function

### 1 Type of charging protection cable



Lightning coiled cable



Type -c coiled cable



Micro -usb coiled cable

### 3 Installation way with desktop



using 3M adhesive

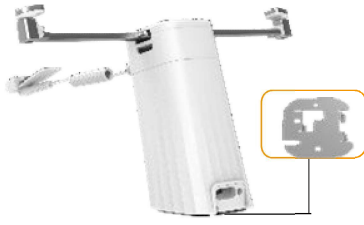

using metal fixing plate

### 2 Components

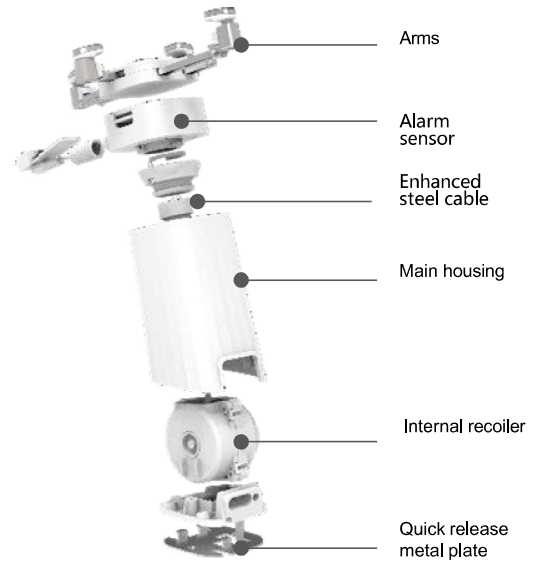

## Product dimension

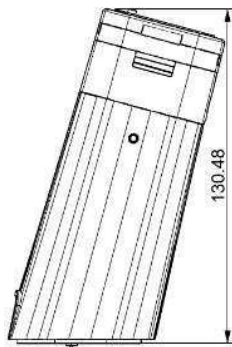

Left view

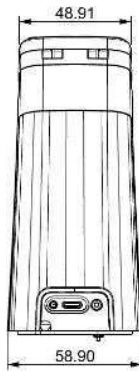

Back view

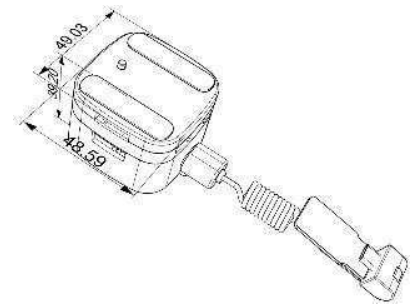

Protection sensor

## Clamp protection range

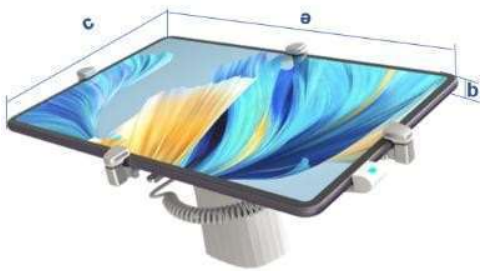

### The width and thickness range of clamp protection

Unit(mm)	Code	Width a	Thickness b	
Two-way protection Range	DE30MA-1	$57 \leq a \leq 90$	$6 \leq b \leq 11$	
	DE30MA-2	$140 \leq a \leq 245$	$6 \leq b \leq 11$	
Four-way protection Range	Code	Width a	Length c	Thickness b
	PJ040	$57 \leq a \leq 90$	$110 \leq c \leq 190$	$6 \leq b \leq 11$
	PJ041	$110 \leq a \leq 190$	$140 \leq c \leq 245$	$6 \leq b \leq 11$

**STG** wearable series



The new generation of internal recoiler display protection and anti-theft device, continuing the "simple and easy to use" design style, perfectly display the smart watch at a 60° Angle, with high security password management system, modular design, rapid disassembly and so on, providing a full range of display anti - theft services for merchandise.

## Features

- Stylish but Streamlined Design;
- Internal secured recoiler: cable with 32" pull length,Simplified aftersales enabled;
- Multiple security level choices: Enhanced protection;
- Enhanced steel cable with shear resistance 20kgf;
- Alarm-on-merchandise with 90 dB alarm;
- Quick release sensor with Eastops anti theft screwdriver;
- 360 degree lockdown for added security;
- Optional split type steel security arms 4;
- USB-A power interface with contact charging pins (5V, 2A);
- Support original charging base USB-A, Type-C interface



Support original charging base  
cable length 100cm



Support display smartwatch  
size 39 ~ 54mm



e-Tops



## Structure function

### 1 Type of original base

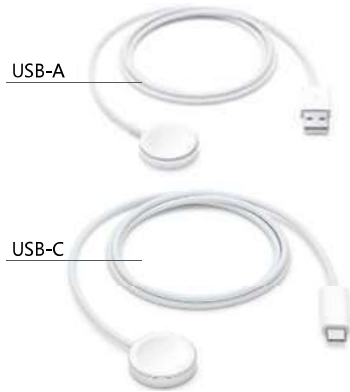

### 2 Installation way with desktop



### 3 Components

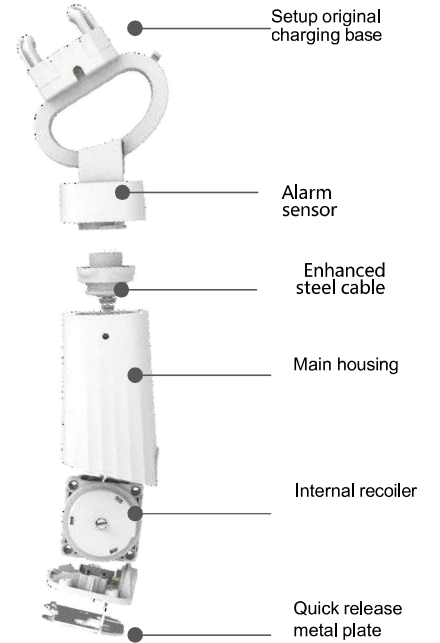

## Product dimension

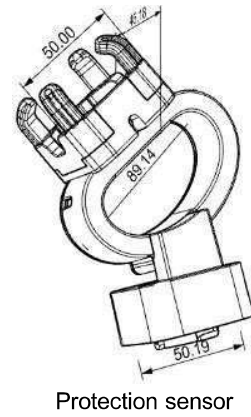
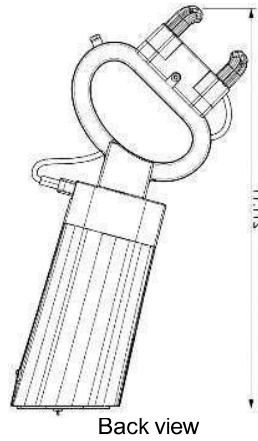

## Clamp protection range



### The width and thickness range of clamp protection

Unit(mm)	Code	Width a	Thickness b
Four-way protection Range	DE30WA	$39 \leq a \leq 54$	$6 \leq b \leq 11$

# STGpro Phoneseries



The new generation of desktop and brackets display anti-theft device, continuing the "simple and easy to use" design style, perfectly display the phone/tablet at a 180° Angle, with high security password management system, modular design, rapid disassembly and so on, providing a full range of display anti - theft services for merchandise.

## Features

- Stylish but streamlined design;
- Telescopic cable: cable with 32" pull length, Simplified aftersales enabled;
- Multiple security level choices: Standard, Enhanced or High protection;
- Enhanced steel cable with shear resistance 20kgf;
- Alarm-on-merchandise with 90 dB alarm;
- Quick release sensor with Eastops anti theft screwdriver;
- 360 degree lockdown for added security;
- Optional split type steel security arms (2 or 4);
- USB-A power interface with contact charging pins (5V, 2A)



standard cable  
(diameter 3.1 and length 100cm)



Standard security  
3M adhesive fixed phone/tablet



e-Tops

## Structure function

### 1 Type of charging security cable

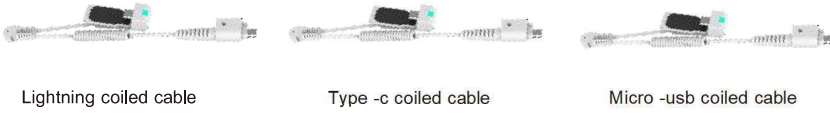

### 2 Components



### 3 Installation way with desktop

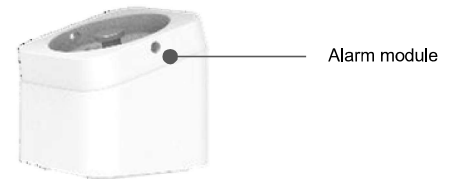

## Product dimension

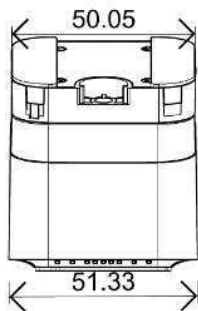

Left view

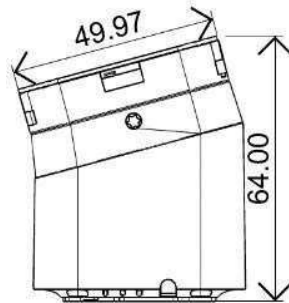

Back view

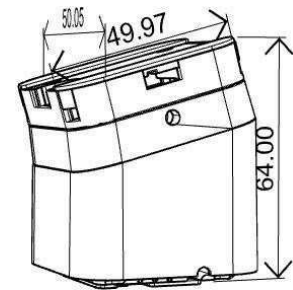

Protection sensor

## Clamp protection range



### The width and thickness range of clamp protection

Unit(mm)	Code	Width a	Thickness b	
Two-way protection Range	PJ018A	$57 \leq a \leq 90$	$6 \leq b \leq 11$	
Four-way protection Range	Code	Width a	Length c	Thickness b
	PJ018C	$57 \leq a \leq 90$	$110 \leq c \leq 190$	$6 \leq b \leq 11$

# STGpro Tabletseries

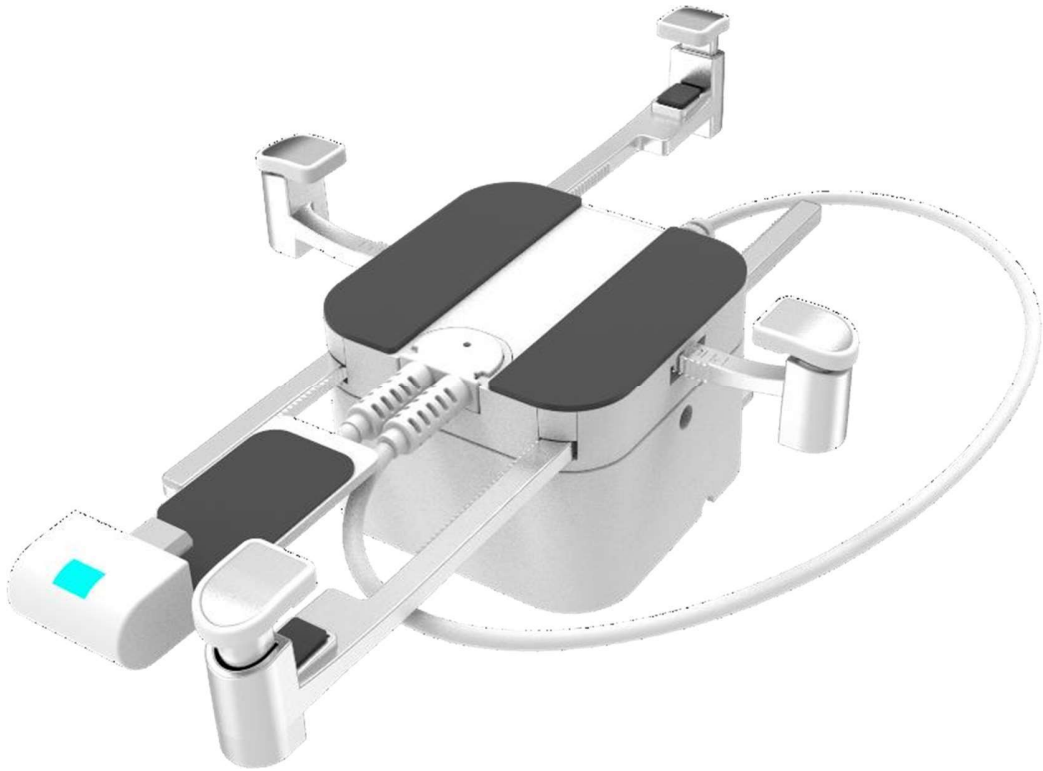



The new generation of desktop and brackets display anti-theft device, continuing the "simple and easy to use" design style, perfectly display the phone/tablet at a 180° Angle, with high security password management system, modular design, rapid disassembly and so on, providing a full range of display anti - theft services for merchandise.

## Features

- Stylish but streamlined design;
- Telescopic cable: cable with 32" pull length, Simplified aftersales enabled;
- Multiple security level choices: Standard, Enhanced or High protection;
- Enhanced steel cable with shear resistance 20kgf;
- Alarm-on-merchandise with 90 dB alarm;
- Quick release sensor with Eastops anti theft screwdriver;
- 360 degree lockdown for added security;
- Optional split type steel security arms (2 or 4);
- USB-A power interface with contact charging pins (5V, 2A)

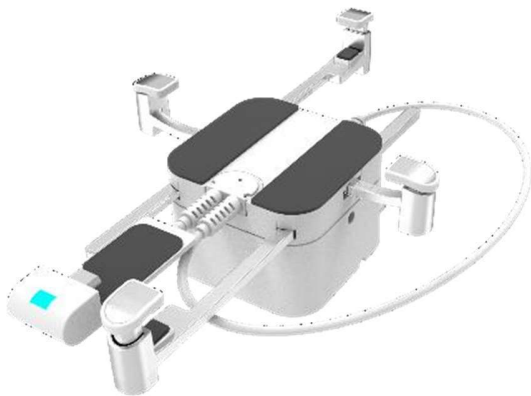

Metal fixing plate  
phone/tablet

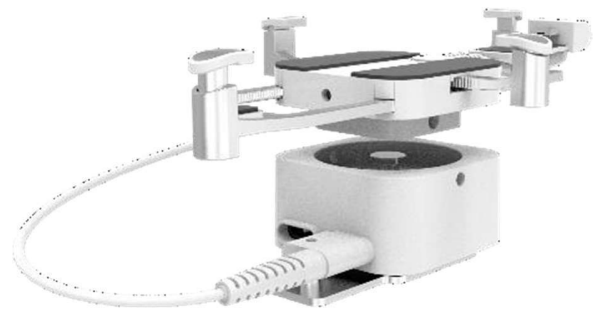

Enhanced steel cable  
( diameter 3.5 and length 70cm)



e-Tops

## Structure function

### 1 Type of charging security cable



Lightning coiled cable



Type -c coiled cable



Micro -usb coiled cable

### 2 Components

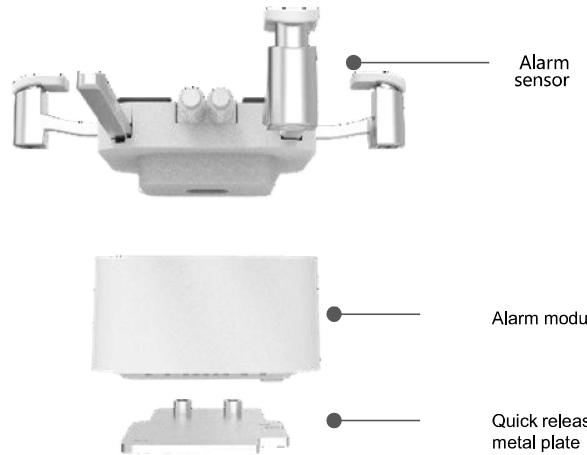

### 3 Installation way with desktop

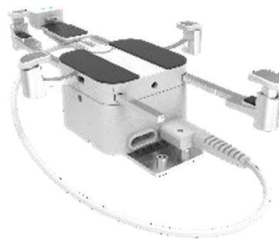

using metal fixing plate

## Product dimension

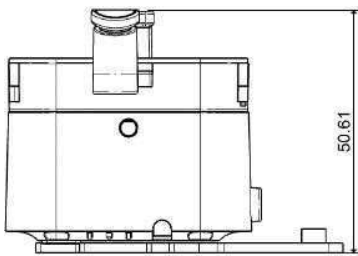

Left view

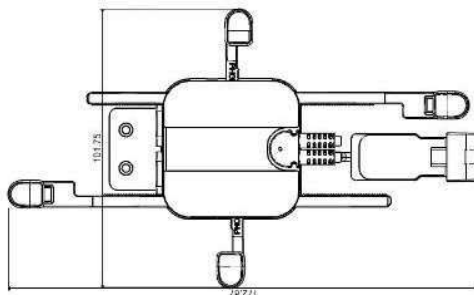

Back view

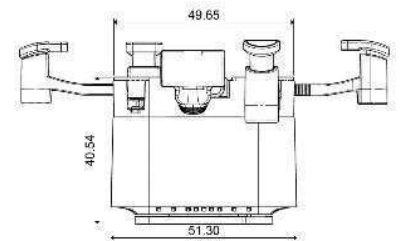

Protection sensor

## Clamp protection range



### The width and thickness range of clamp protection

Unit(mm)	Code	Width a	Thickness b	
Two-way protection Range	PJ018E	$140 \leq a \leq 245$	$6 \leq b \leq 11$	
Four-way protection Range	Code	Width a	Length c	Thickness b
	PJ018F	$110 \leq a \leq 190$	$140 \leq c \leq 245$	$6 \leq b \leq 11$

**STGpro** Wearable series

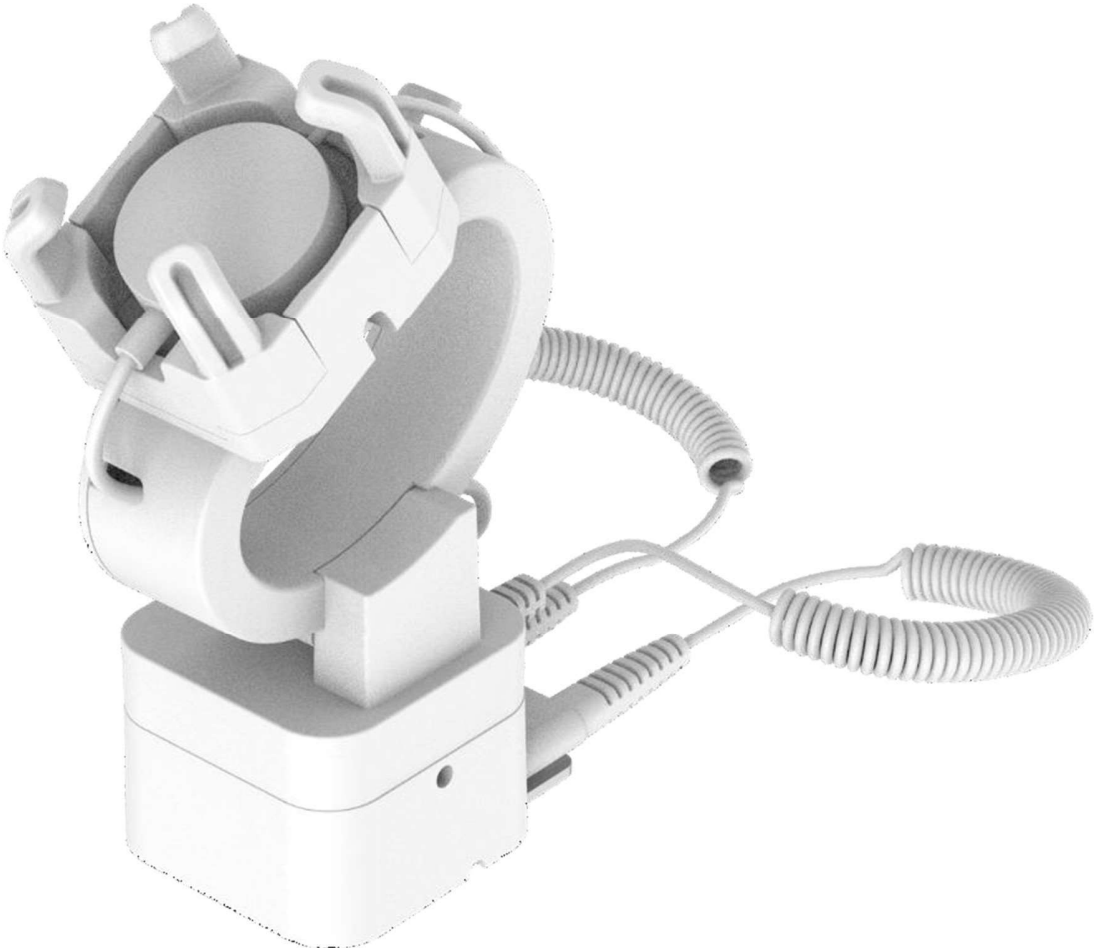

The new generation of desktop display anti-theft device, continuing the "simple and easy to use" design style, perfectly display the smart watch at a 60° Angle, with high security password management system, modular design, rapid disassembly and so on, providing a full range of display anti - theft services for merchandise.

## Features

- Stylish but streamlined design;
- Telescopic cable: cable with 32" pull length, Simplified aftersales enabled;;
- Multiple security level choices: Enhanced protection;
- Alarm-on-merchandise with 90 dB alarm;
- Quick release sensor with Eastops anti theft screwdriver;
- 360 degree lockdown for added security;
- Standard cable with tensile resistance 10kgf;
- USB-A power interface with contact charging pins (5V, 2A);
- Support original charging base USB-A, Type-C interface



3M adhesive fixed phone/tablet



e-Tops



Standard cable  
( diameter 2.0 and length 100cm)

## Structure function

### 1 Type of original base



### 3 Installation way with desktop



### 2 Components

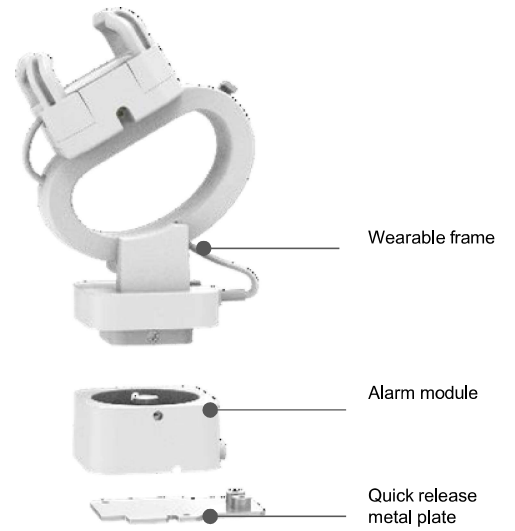

## Product dimension

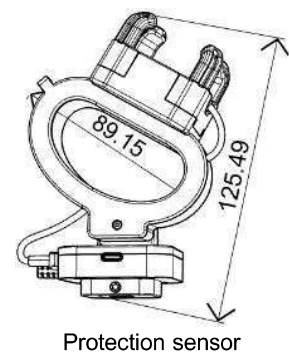
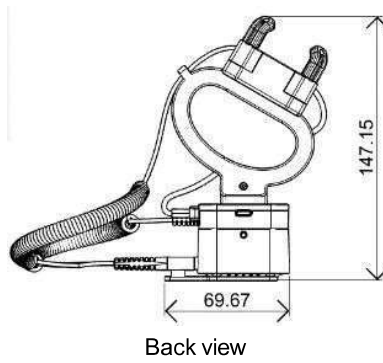
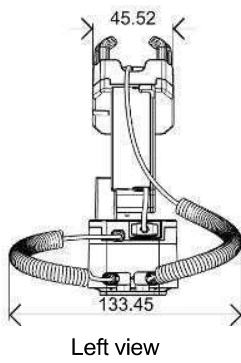

## Clamp protection range



### The width and thickness range of clamp protection

Unit(mm)	Code	Width a	Thickness b
Four-way protection Range	DE31WA	$39 \leq a \leq 54$	$6 \leq b \leq 11$

**STGpro** Headphoneseries



The new generation of desktop and brackets display anti-theft device, continuing the "simple and easy to use" design style, perfectly display the smart watch at a 180° Angle, with high security password management system, modular design, rapid disassembly and so on, providing a full range of display anti - theft services for merchandise.

## Features

- Stylish but streamlined design;
- Telescopic cable: cable with 32" pull length, Simplified aftersales enabled;
- Multiple security level choices: Standard, protection;
- Standard cable with tensile resistance 10kgf;
- Alarm-on-merchandise with 90 dB alarm;
- Quick release sensor with Eastops anti theft screwdriver;
- Charging anti-theft separation solution, lower false alarm probability;
- USB-A power interface with contact charging pins (5V, 2A)



phone/tablet



Standard cable  
( diameter 2.0 and length 100cm)



e-Tops

## Structure function

### 1 Type of alarm security cable



### 3 Installation way with desktop



using 3M adhesive



using metal fixing plate

### 2 Components

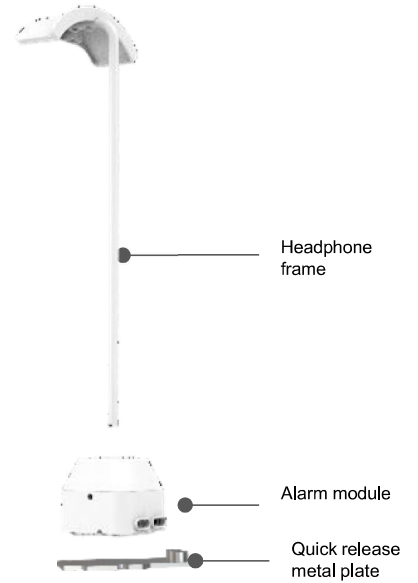

## Product dimension

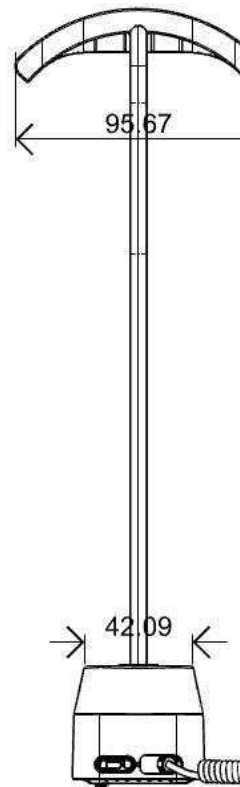

Left view

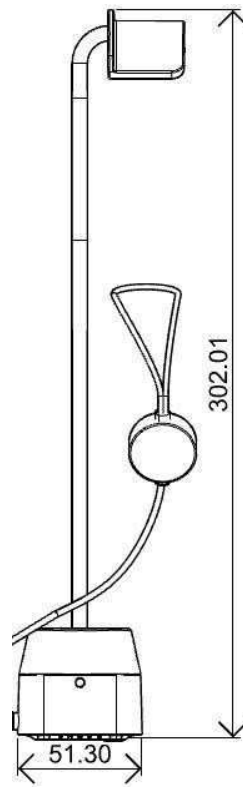

Back view



**STGpro** Camera series



The new generation of desktop display anti-theft device, continuing the "simple and easy to use" design style, perfectly display the smart watch at a 180° Angle, with high security password management system, modular design, rapid disassembly and so on, providing a full range of display anti - theft services for merchandise.

## Features

- Stylish but streamlined design;
- Telescopic cable: cable with 32" pull length, Simplified aftersales enabled;
- Multiple security level choices: Standard, protection;
- Standard cable with tensile resistance 10kgf;
- Alarm-on-merchandise with 90 dB alarm;
- Quick release sensor with Eastops anti theft screwdriver;
- Charging anti-theft separation solution, lower false alarm probability;
- USB-A power interface with contact charging pins (5V, 2A)



3M adhesive fixed  
phone/tablet



e-Tops



Standard cable  
( diameter 2.0 and length 100 cm)

## Structure function

### 1 Type of alarm security cable



### 3 Installation way with desktop



using 3M adhesive



using metal fixing plate

### 2 Components

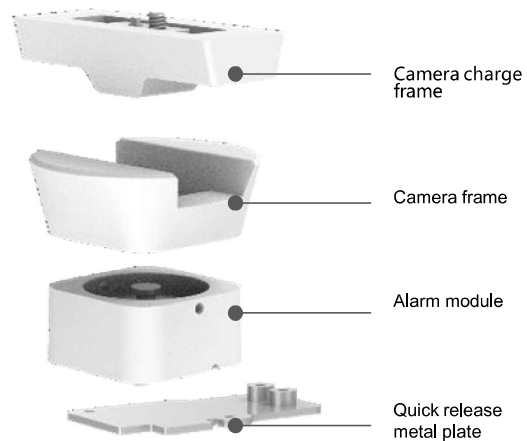

## Product dimension

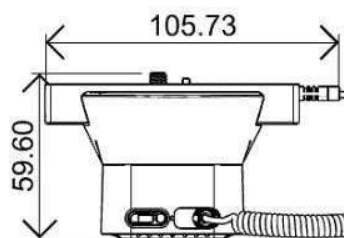

Left view

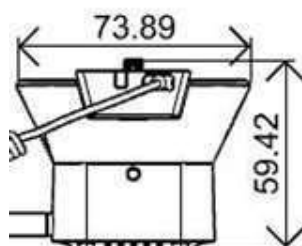

Back view

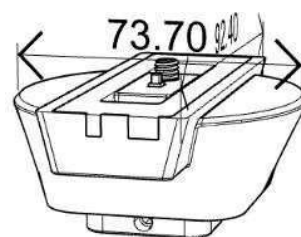

Protection sensor

# STGpro IOT series



The new generation of desktop and brackets display anti-theft device, continuing the "simple and easy to use" design style, perfectly display the IOT product etc. , with high security password management system, modular design, rapid disassembly and so on, providing a full range of display anti - theft services for merchandise.

## Features

- Stylish but streamlined design;
- Telescopic cable: cable with 32" pull length,Simplified aftersales enabled;
- Multiple security level choices: Standard, protection;
- Standard cable with tensile resistance 10kgf;
- Alarm-on-merchandise with 90 dB alarm;
- Quick release sensor with Eastops anti theft screwdriver;
- Charging anti-theft separation solution, lower false alarm probability;
- USB-A power interface with contact charging pins (5V, 2A)



3M adhesive fixed phone/tablet



3M adhesive fixed phone/tablet



3M adhesive fixed phone/tablet



## Structure function

### 1 Type of alarm security cable

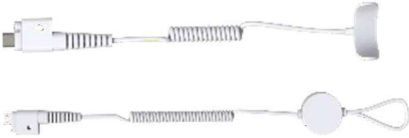

### 3 Installation way with desktop



using 3M adhesive



using metal fixing plate

### 2 Components

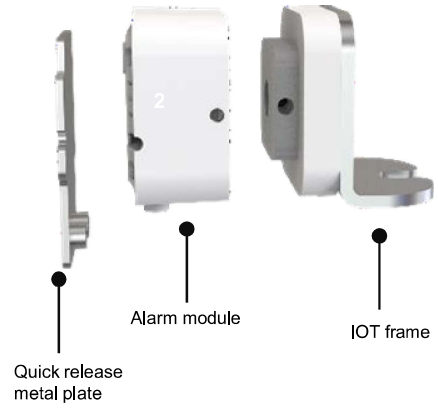

## Product dimension

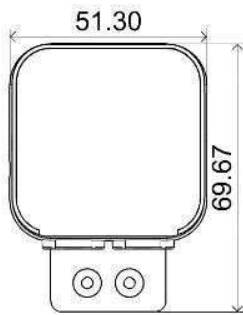

Left view

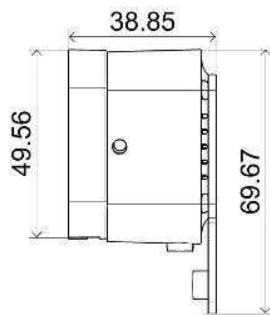

Back view

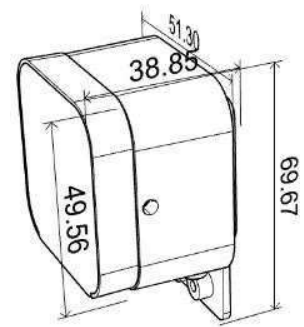

Protection sensor

# LTG Phoneseries



The new generation of internal recoiler display protection and anti-theft device, continuing the "simple and easy to use" design style, perfectly display the phone/tablet at a 75° Angle, with standard security password management system, modular design, rapid disassembly and so on, providing a full range of display anti - theft services for merchandise.

## Features

- Stylish but streamlined design;
- Internal secured recoiler: cable with 32" pull length, Simplified aftersales enabled;
- Multiple security level choices: Standard protection;
- Standard cable with tensile resistance 10kgf;
- Alarm-on-merchandise with 90 dB alarm;
- Quick release sensor with Eastops anti theft screwdriver;
- 360 degree lockdown for added security;
- Wireless alarm sensor optional;
- USB-A power interface with contact charging pins (5V, 2A)



Wireless / Standard security  
3M adhesive fixed phone/tablet



Standard cable  
(diameter 2.0 and length 80cm)



e-Tops



## Structure function

### 1 Type of charging security cable



Lightning coiled cable



Type -c coiled cable



Micro -usb coiled cable

### 3 Installation way with desktop



3M adhesive

### 2 Components

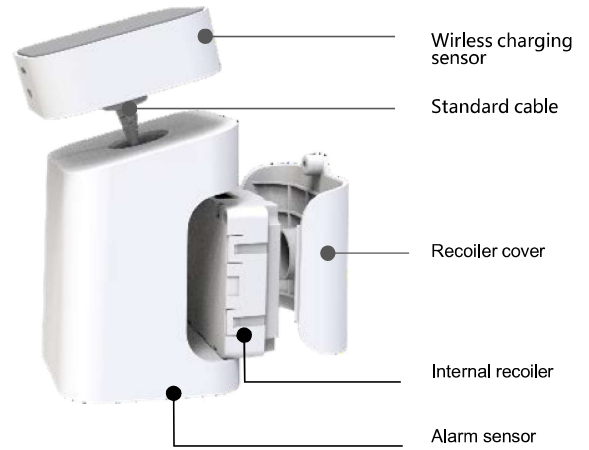

## Product dimension

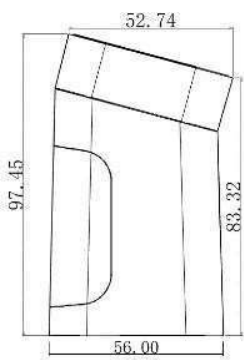

Left view

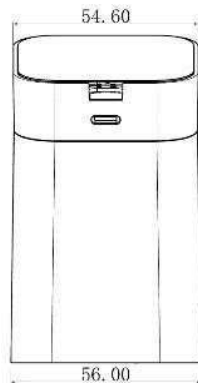

Back view

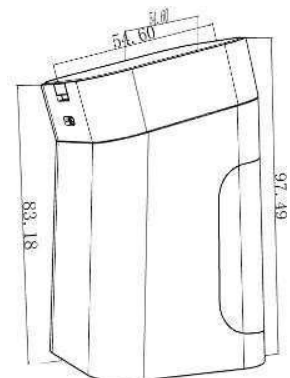

Protection sensor

# LTG Tabletseries



The new generation of internal recoiler display protection and anti-theft device, continuing the "simple and easy to use" design style, perfectly display the phone/tablet at a 75° Angle, with standard security password management system, modular design, rapid disassembly and so on, providing a full range of display anti - theft services for merchandise.

## Features

- Stylish but streamlined design;
- Internal secured recoiler: cable with 32" pull length, Simplified aftersales enabled;
- Multiple security level choices: Standard protection;
- Standard cable with tensile resistance 10kgf;
- Alarm-on-merchandise with 90 dB alarm;
- Quick release sensor with Eastops anti theft screwdriver;
- 360 degree lockdown for added security;
- Wireless alarm sensor optional;
- USB-A power interface with contact charging pins (5V, 2A)

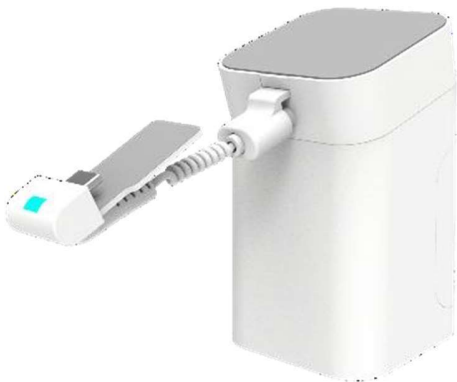

Wireless / Standard security  
3M adhesive fixed phone/tablet



Standard cable  
(diameter 2.0 and length 80cm)



e-Tops

## Structure function

### 1 Type of charging security cable



Lightning coiled cable



Type -c coiled cable



Micro -usb coiled cable

### 3 Installation way with desktop



3M adhesive

### 2 Components

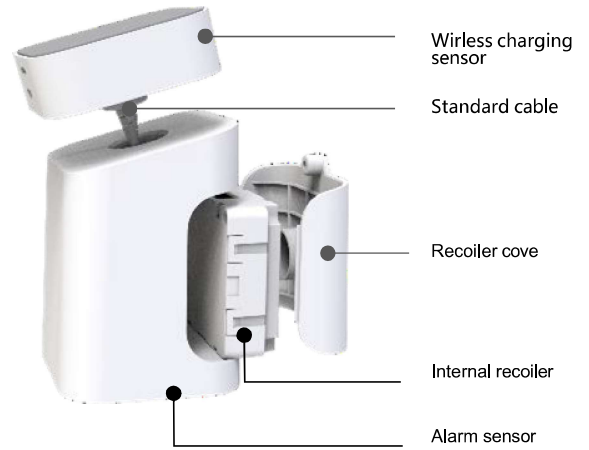

## Product dimension

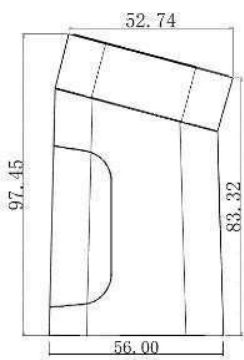

Left view

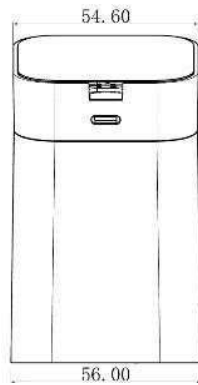

Back view

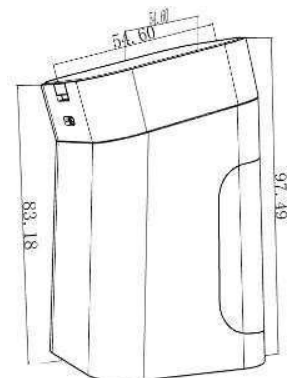

Protection sensor

**LTG** Wearable series



The new generation of internal recoiler display protection and anti-theft device, continuing the "simple and easy to use" design style, perfectly display the wearable at a 75° Angle, with standard security password management system, modular design, rapid disassembly and so on, providing a full range of display anti - theft services for merchandise.

## Features

- Stylish but streamlined design;
- Internal secured recoiler: cable with 32" pull length, Simplified aftersales enabled;
- Multiple security level choices: Standard protection;
- Standard cable with tensile resistance 10kgf;
- Alarm-on-merchandise with 90 dB alarm;
- Quick release sensor with Eastops anti theft screwdriver;
- 360 degree lockdown for added security;
- Split type ABS security arms 2;
- USB-A power interface with contact charging pins (5V, 2A);
- Support original charging base USB-A, Type-C interface



Enhanced security  
ABS+2-way arms for wearable



Standard cable  
(diameter 2.0 and length 80cm)



e-Tops

## Structure function

### 1 Type of original base



### 3 Installation way with desktop



using 3M adhesive

### 2 Components

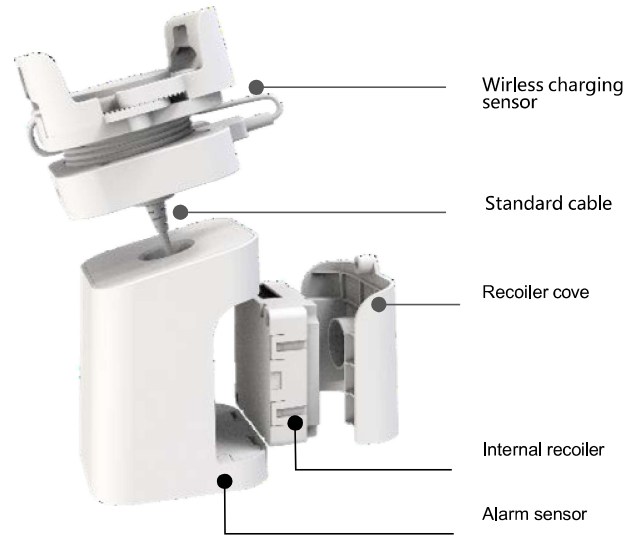

## P roduct dimension

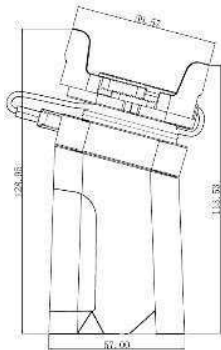

Left view

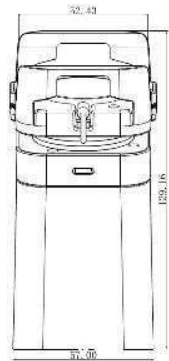

Back view

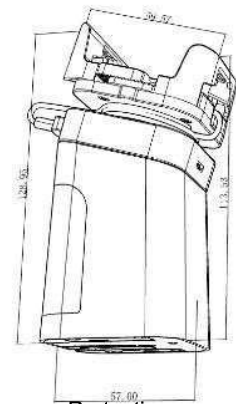

Protection sensor

## C lamp protection range



### The width and thickness range of clamp protection

Unit(mm)	Code	Width a	Thickness b
Four-way protection Range	DE40WA	$39 \leq a \leq 54$	$6 \leq b \leq 11$

# LTG Cameraseries





The new generation of internal recoiler desktop display protection and anti-theft device, continuing the "simple and easy to use" design style, perfectly display the camera at a 180° Angle, with standard security password management system, modular design, rapid disassembly and so on, providing a full range of display anti - theft services for merchandise.

## Features

- Stylish but streamlined design;
- Internal secured recoiler: cable with 32" pull length, Simplified aftersales enabled;
- Multiple security level choices: Standard protection;
- Standard cable with tensile resistance 10kgf;
- Alarm-on-merchandise with 90 dB alarm;
- Quick release sensor with Eastops anti theft screwdriver;
- 360 degree lockdown for added security;
- USB-A power interface with contact charging pins (5V, 2A)



Standard security  
3M adhesive fixed camera



e-Tops



Standard cable  
(diameter 2.0 and length 80cm)

## Structure function

### 1 Type of alarm security cable



Alarm sensor cable

### 3 Installation way with desktop



using 3M adhesive

### 2 Components

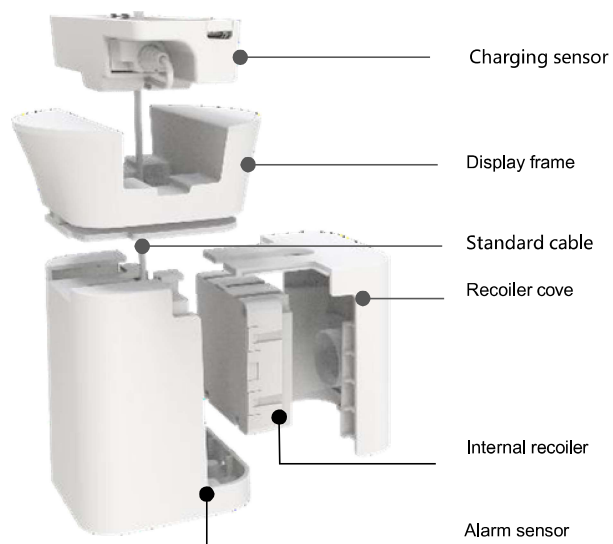

## Product dimension

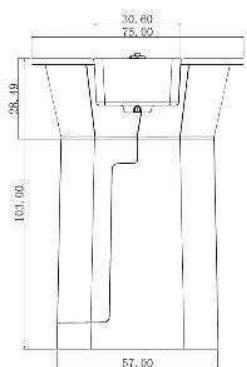

Left view

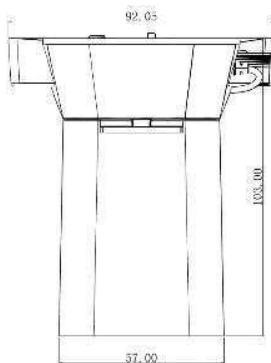

Back view

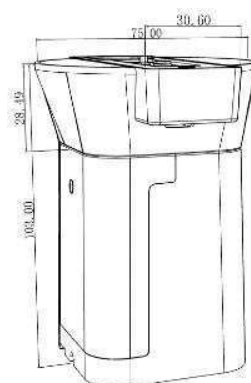

Protection sensor

# LTG IOT series



The new generation of internal recoiler desktop and brackets display protection and anti-theft device, continuing the "simple and easy to use" design style, perfectly display the IOT, with standard security password management system, modular design, rapid disassembly and so on, providing a full range of display anti - theft services for merchandise.

## Features

- Stylish but streamlined design;
- Internal secured recoiler: cable with 32" pull length,Simplified aftersales enabled;
- Multiple security level choices: Standard protection;
- Standard cable with tensile resistance 10kgf;
- Alarm-on-merchandise with 90 dB alarm;
- Quick release sensor with Eastops anti theft screwdriver;
- 360 degree lockdown for added security;
- Support different display frames can be replaced;
- USB-A power interface with contact charging pins (5V, 2A)



e-Tops



Support different display frames  
can be replaced

## Structure function

### 1 Type of alarm security recoiler



### 3 Installation way with desktop



using 3M adhesive

### 2 Components



## Product dimension

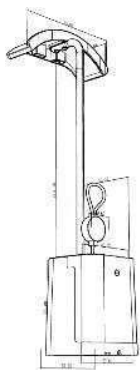

Left view

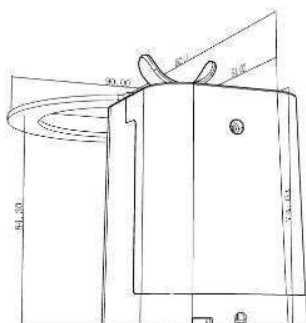

Back view

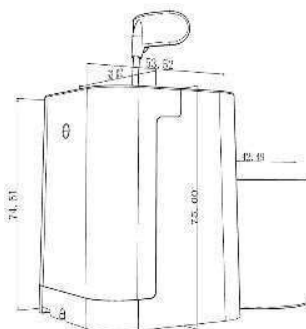

Protection sensor

# LTG IOT brackets series



The new generation of internal recoiler desktop and brackets display protection and anti-theft device, continuing the "simple and easy to use" design style, perfectly display the IOT, with standard security password management system, modular design, rapid disassembly and so on, providing a full range of display anti - theft services for merchandise.

## Features

- Stylish but streamlined design;
- Internal secured recoiler: cable with 32" pull length,Simplified aftersales enabled;
- Multiple security level choices: Standard protection;
- Standard cable with tensile resistance 10kgf;
- Alarm-on-merchandise with 90 dB alarm;
- Quick release sensor with Eastops anti theft screwdriver;
- 360 degree lockdown for added security;
- Support different display frames can be replaced;
- USB-A power interface with contact charging pins (5V, 2A)



e-Tops



Support different display frames  
can be replaced

## Structure function

### 1 Type of alarm security recoiler



### 3 Installation way with desktop



using 3M adhesive

### 2 Components

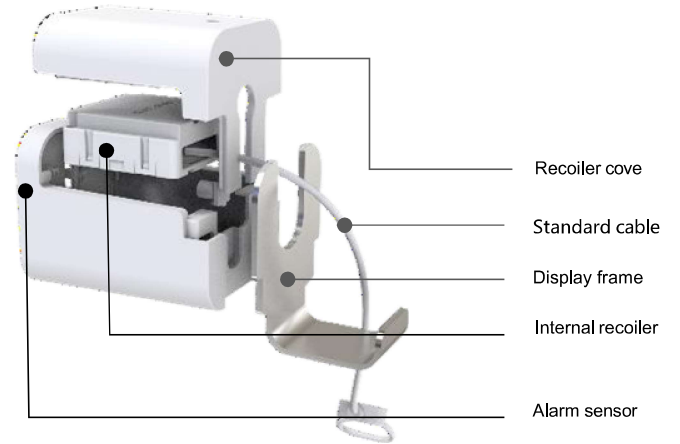

## Product dimension

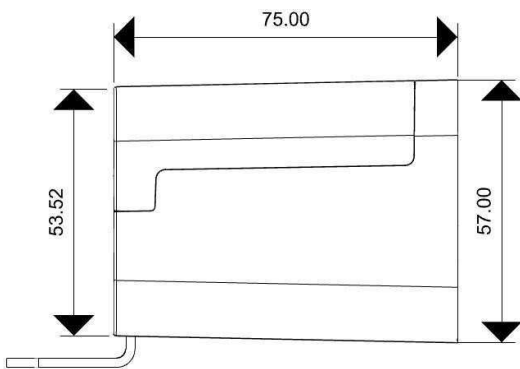

Left view

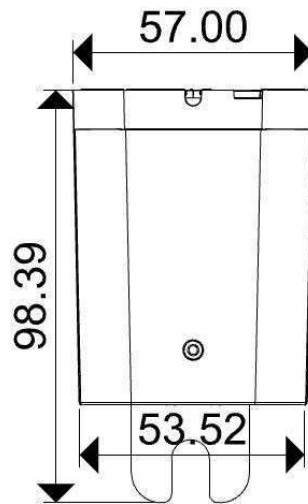

Back view

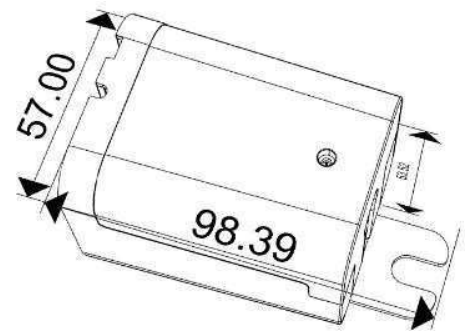

Protection sensor



# LTGpro Phone series



The new generation of internal recoiler display protection and anti-theft device, continuing the "simple and easy to use" design style, perfectly display the phone at a 15° Angle, with standard security password management system, modular design, rapid disassembly and so on, providing a full range of display anti - theft services for merchandise.

## Features

- Stylish but streamlined design;
- Internal secured recoiler: cable with 32" pull length, Simplified aftersales enabled;
- Multiple security level choices: Standard, protection;
- Standard steel cable with tensile resistance 10kgf;
- Alarm-on-merchandise with 90 dB alarm;
- Quick release sensor with Eastops anti theft screwdriver;
- Charging anti-theft separation solution, lower false alarm probability;
- USB-A power interface with contact charging pins (5V, 2A)



Standard security  
3M adhesive fixed  
phone

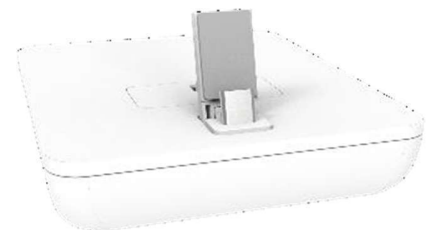

advanced cable  
(diameter 2.0 and length 80cm)



e-Tops

## Structure function

### 1 Installation way with desktop



using 3M adhesive

### 2 Components

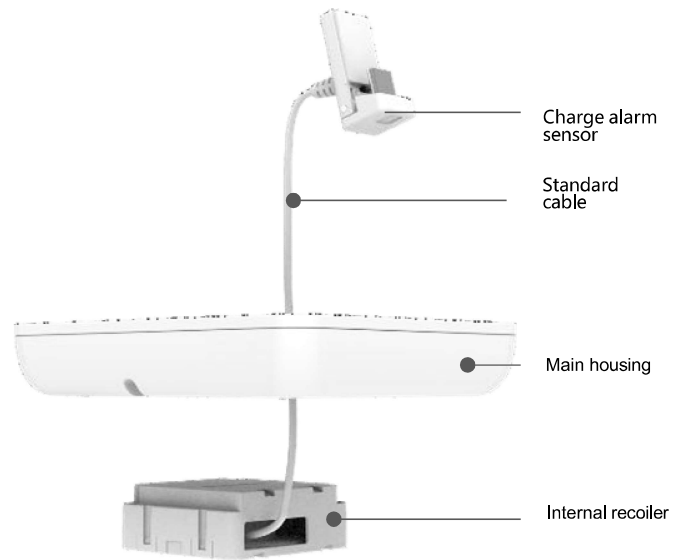

## Product dimension

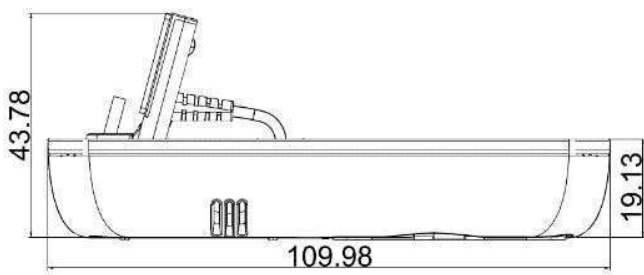

Left view

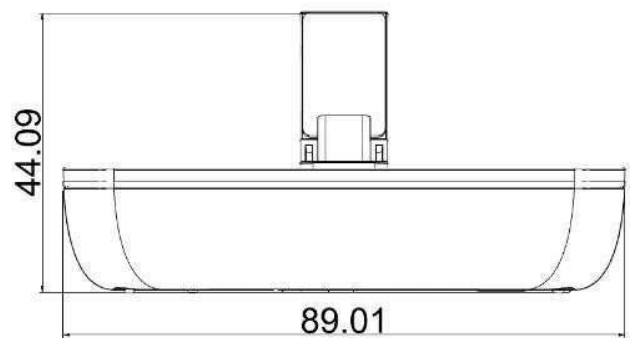

Front view

# LTGpro Wearable series



The new generation of internal recoiler display protection and anti-theft device, continuing the "simple and easy to use" design style, perfectly display the wearable at a 180° Angle, with standard security password management system, modular design, rapid disassembly and so on, providing a full range of display anti - theft services for merchandise.

## Features

- Stylish but streamlined design;
- Internal secured recoiler: cable with 32" pull length, Simplified aftersales enabled;
- Multiple security level choices: Standard, protection;
- Standard steel cable with tensile resistance 10kgf;
- Alarm-on-merchandise with 90 dB alarm;
- Quick release sensor with Eastops anti theft screwdriver;
- Charging anti-theft separation solution, lower false alarm probability;
- USB-A power interface with contact charging pins (5V, 2A);
- Support original charging base USB-A, Type-C interface



Standard security  
3M adhesive fixed  
wearable



advanced cable  
(diameter 2.0 and length 80cm)



e-Tops

## Structure function

### 1 Installation way with desktop



using 3M adhesive

### 2 Components

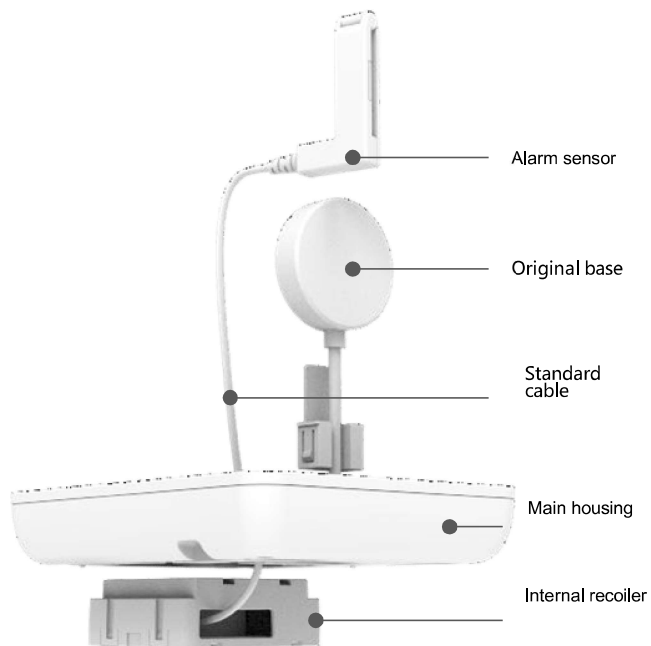

## Product dimension

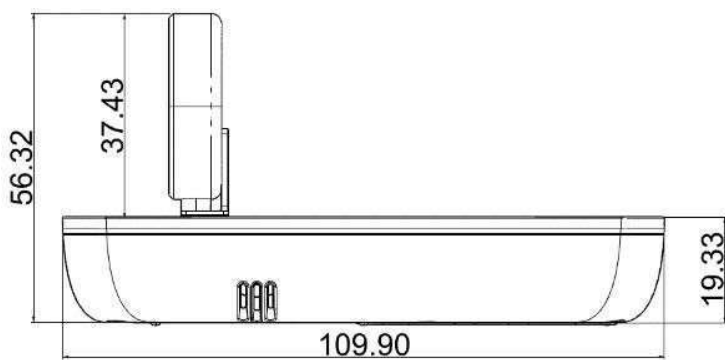

Left view

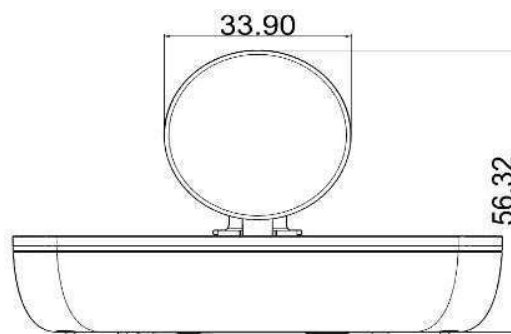

Front view

# LTGpro Phone+Wearable series



The new generation of internal recoiler display protection and anti-theft device, continuing the "simple and easy to use" design style, perfectly display the wearable at a 180° Angle, with standard security password management system, modular design, rapid disassembly and so on, providing a full range of display anti - theft services for merchandise.

## Features

- Stylish but streamlined design;
- Internal secured recoiler: cable with 32" pull length, Simplified aftersales enabled;
- Multiple security level choices: Standard, protection;
- Standard steel cable with tensile resistance 10kgf;
- Alarm-on-merchandise with 90 dB alarm;
- Quick release sensor with Eastops anti theft screwdriver;
- Charging anti-theft separation solution, lower false alarm probability;
- USB-A power interface with contact charging pins (5V, 2A);
- Support original charging base USB-A, Type-C interface



Standard security  
3M adhesive fixed  
wearable



e-Tops



advanced cable  
(diameter 2.0 and length 80cm)



## Structure function

### 1 Installation way with desktop

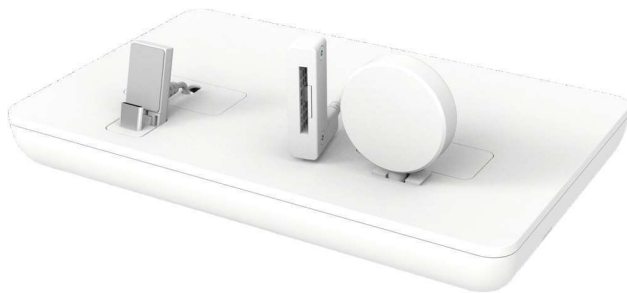

using 3M adhesive

### 2 Components

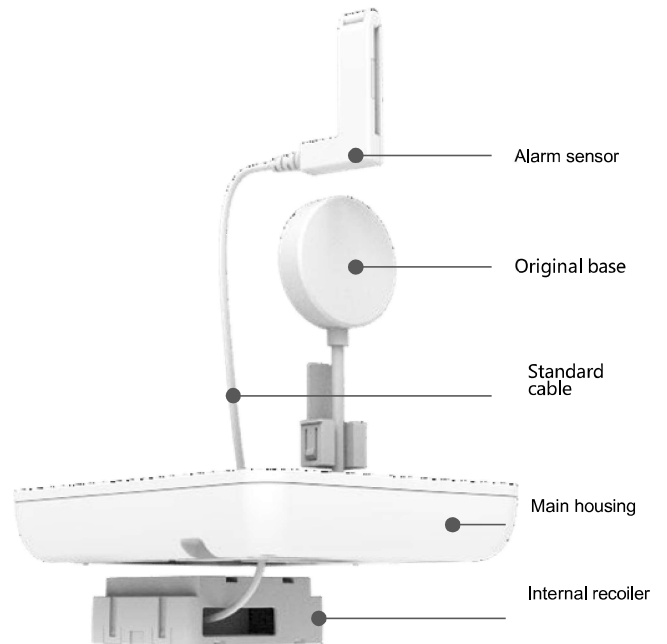

## Product dimension

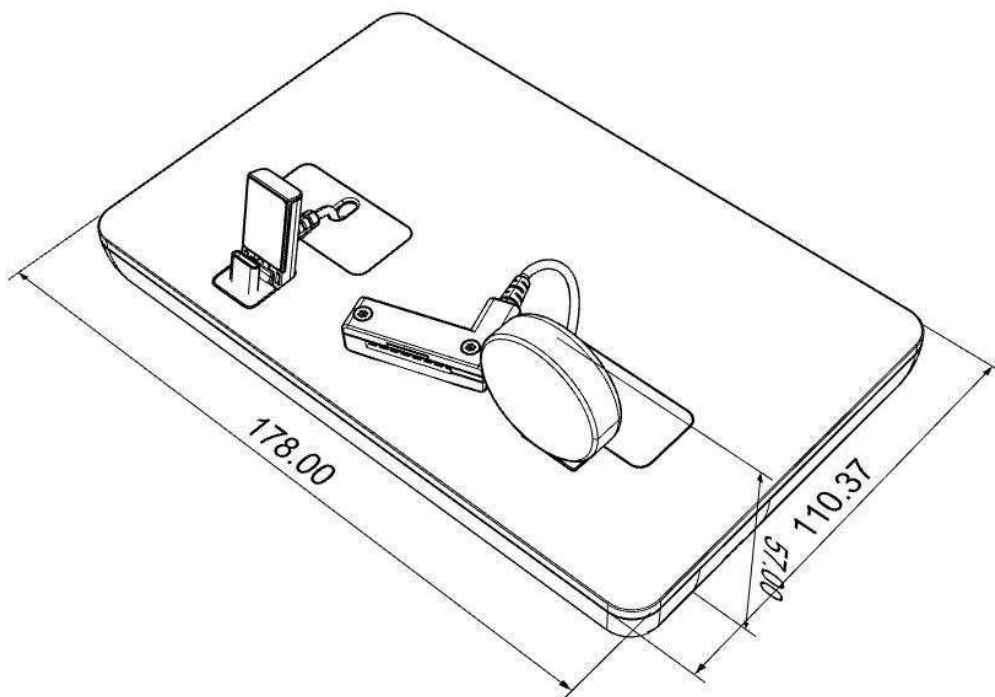

# LTGpro Wearable+Wearable series



The new generation of internal recoiler display protection and anti-theft device, continuing the "simple and easy to use" design style, perfectly display the wearable at a 180° Angle, with standard security password management system, modular design, rapid disassembly and so on, providing a full range of display anti - theft services for merchandise.

## Features

- Stylish but streamlined design;
- Internal secured recoiler: cable with 32" pull length, Simplified aftersales enabled;
- Multiple security level choices: Standard, protection;
- Standard steel cable with tensile resistance 10kgf;
- Alarm-on-merchandise with 90 dB alarm;
- Quick release sensor with Eastops anti theft screwdriver;
- Charging anti-theft separation solution, lower false alarm probability;
- USB-A power interface with contact charging pins (5V, 2A);
- Support original charging base USB-A, Type-C interface



Standard security  
3M adhesive fixed  
wearable



advanced cable  
(diameter 2.0 and length 80cm)



e-Tops

## Structure function

### 1 Installation way with desktop



using 3M adhesive

### 2 Components

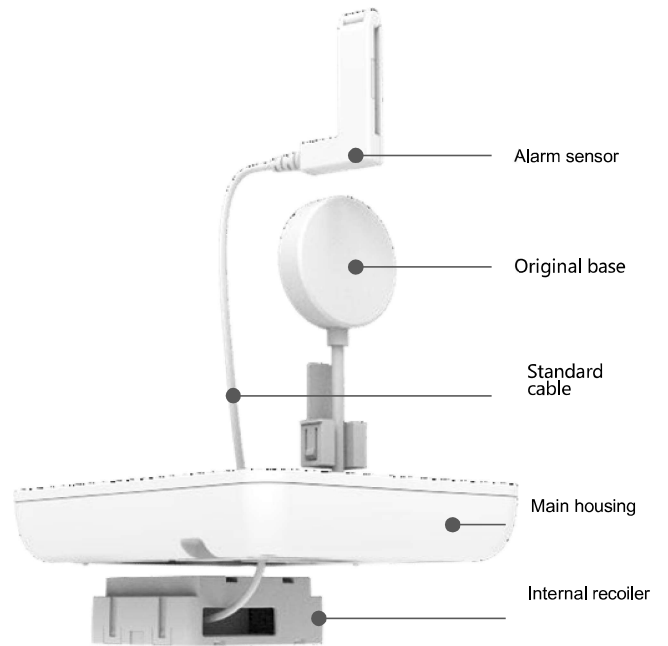

## Product dimension

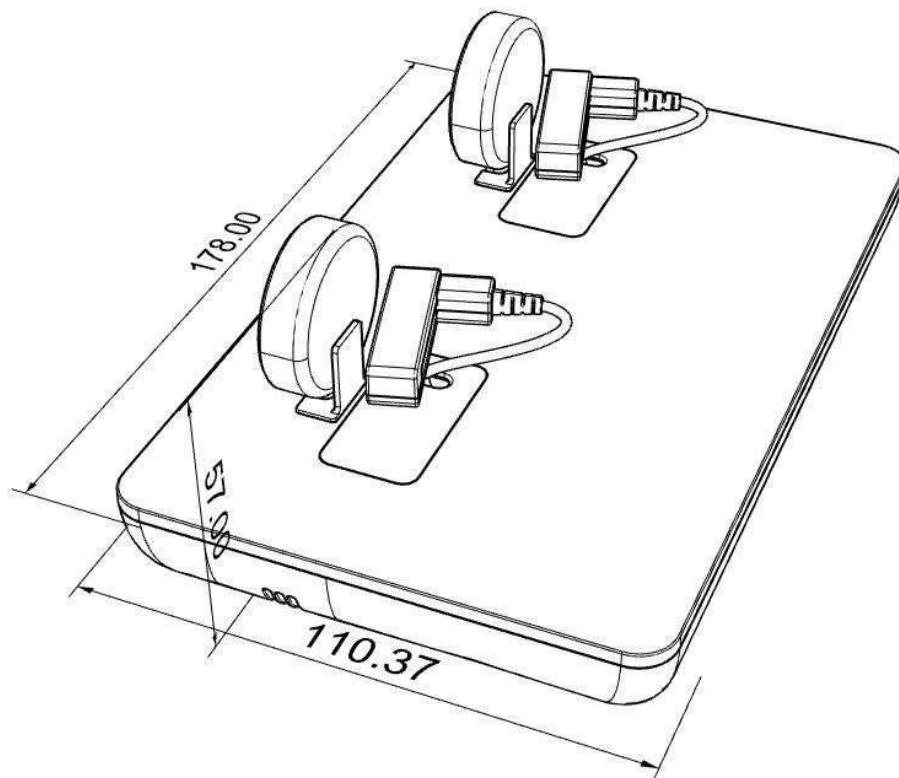

# MP series



The new generation of desktop anti-theft device, continuing the "simple and easy to use" design style, perfectly display the all categories product, modular design, providing a full range of display anti - theft services for merchandise, customizable display brackets for various commodities.

## Features

- Stylish but streamlined design;
- Telescopic cable: cable with 60~80" pull length, Simplified aftersales enabled, longer cables adapt to more scene requirements;
- Multiple security level choices: Standard, protection;
- Standard cable with tensile resistance 10kgf;
- Alarm-on-merchandise with 90 dB alarm;
- Quick release sensor with Eastops anti theft screwdriver;
- Charging anti-theft separation solution, lower false alarm probability;
- USB-A power interface with contact charging pins (5V, 2A)



# SA series

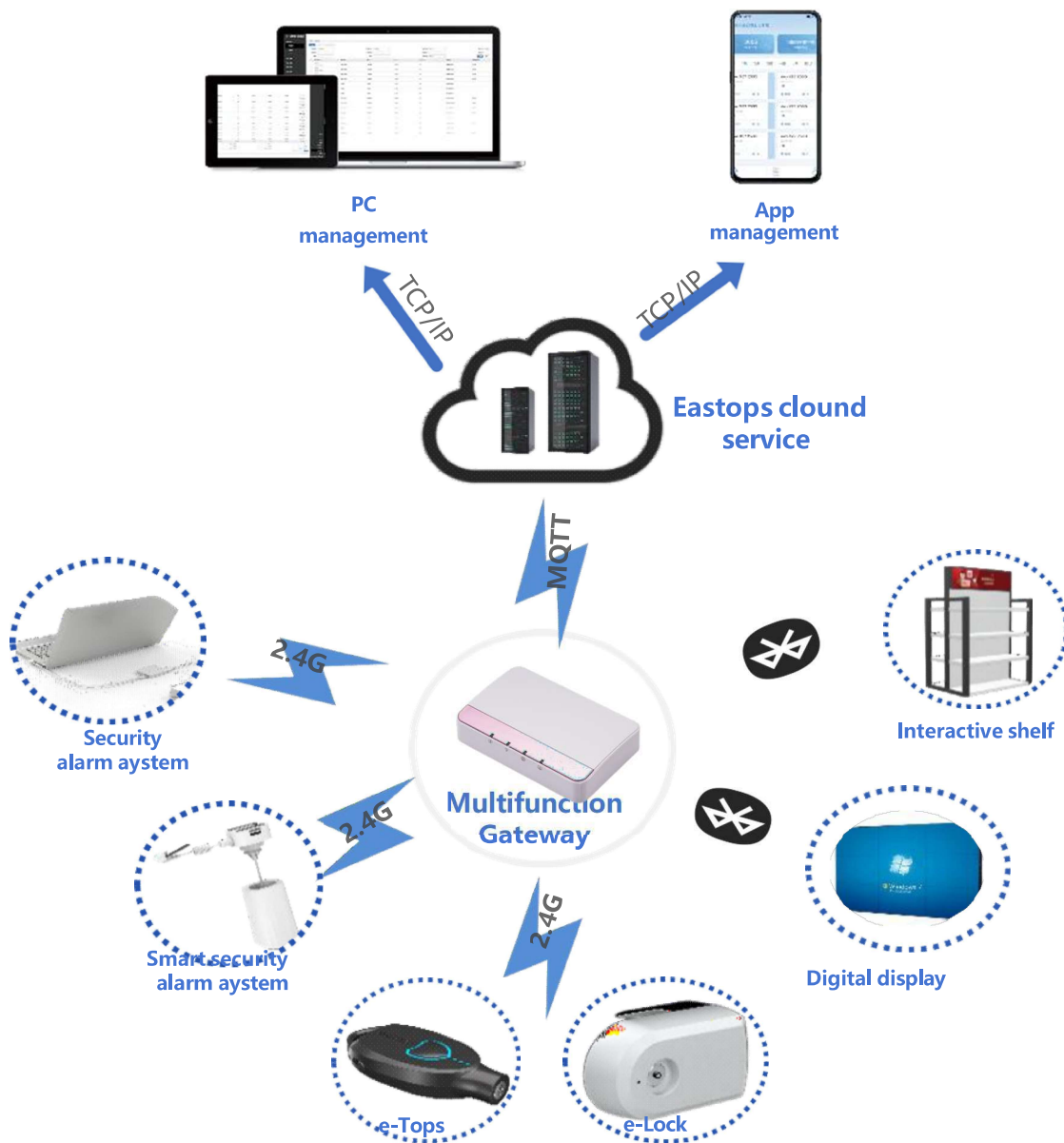

The e-Tops has allowed us to operate more efficiently on the sales floor and serve customers more quickly. everyone having their own key means no one has to share keys, which protects our associates as well as our assets, never worry about lost or stolen keys again.

### Features

- Data transmission through proprietary 2.4G private protocol;
- Includes 3.7 V, 70 mAH Rechargeable Lithium Battery;
- Wireless power transfer capability – Frequency 2.4GHz;
- Electrical Rating: Input 5.0V1A, Output 3.7V 0.07A;
- Color: Black

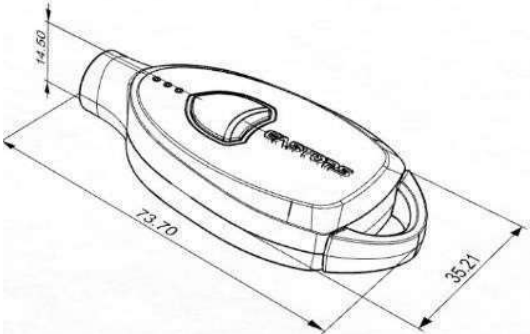



The new generation anti-theft system, continuing the "simple and easy to use" design style, perfectly display the all categories product, modular design, providing a full range of display anti - theft services for merchandise, support the uniqueness of anti-theft keys for various commodities, customize the display style of various commodities, data acquisition, and eastops cloud platform management.

## Features

- Stylish but streamlined design for various passive locks;
- Smart locking solution for single or double swing-out glass doors;
- Compatible with e-Tops;
- No battery or local wiring needed for power;
- Color: Black or White

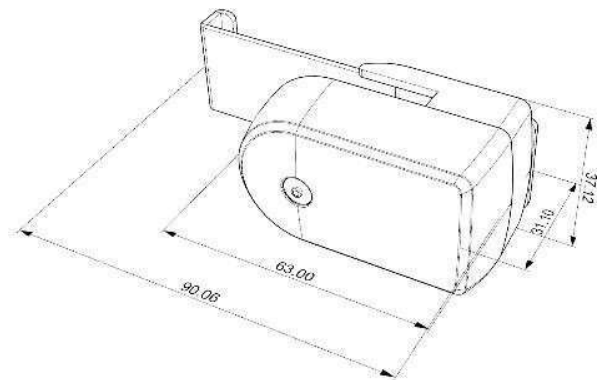

The new generation of PC anti-theft device, continuing the "simple and easy to use" design style, perfectly display the all categories product, modular design, providing a full range of display anti - theft services for merchandise, customizable display brackets for various commodities.

## Features

- Stylish but streamlined design for PC;
- Telescopic cable: cable with 60~80" pull lenth,Simplified aftersales enabled, longer cables adapt to more scene requirements;
- Multiple security level choices: Standard & enhanced protection;
- Standard cable with tensile resistance 10kgf;
- Alarm-on-merchandise with 90 dB alarm;
- Quick release sensor with Eastops anti theft screwdriver;
- Use the original PC adapter

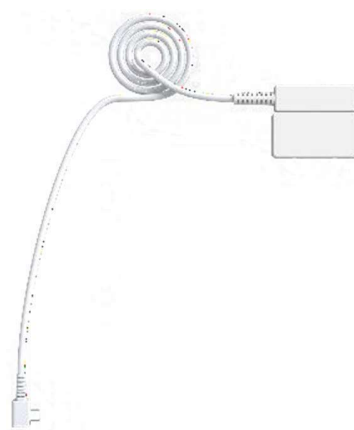
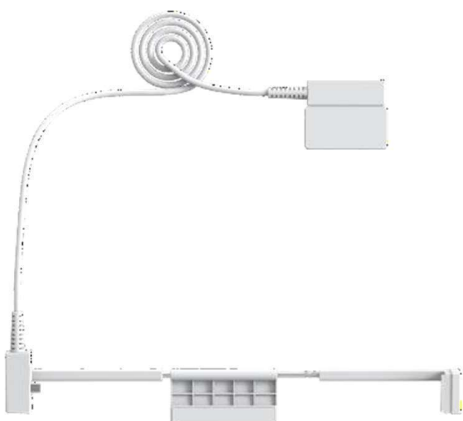
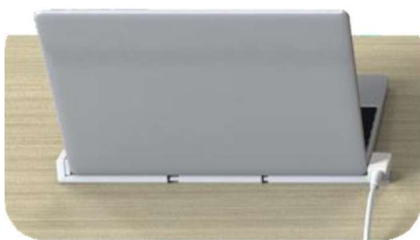

The new generation of Monitor & Desktop Computer(HDMI+USB) anti-theft device, continuing the "simple and easy to use" design style, perfectly display the all categories product, modular design, providing a full range of display anti - theft services for merchandise, customizable display brackets for various commodities.

## Features

- Stylish but streamlined design for Monitor & Desktop Computer(HDMI+USB) ;
- Telescopic cable: cable with 60~80" pull lenth,Simplified aftersales enabled, longer cables adapt to more scene requirements;
- Multiple security level choices: Standard & enhanced protection;
- Standard cable with tensile resistance 10kgf;
- Alarm-on-merchandise with 90 dB alarm;
- Quick release sensor with Eastops anti theft screwdriver;
- Charging anti-theft separation solution, lower false alarm probability;
- USB-A power interface with contact charging pins (5V, 2A)

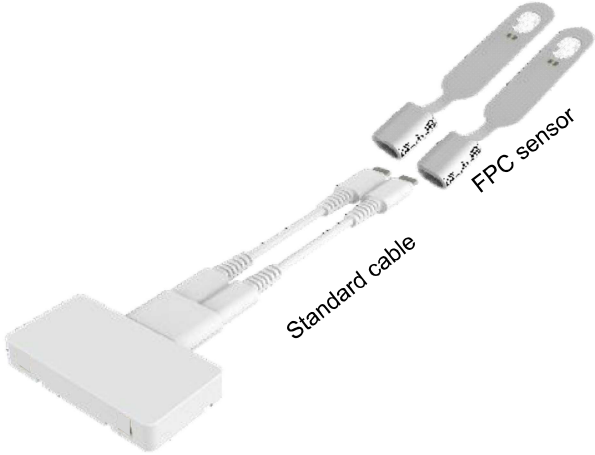

Host



Host



The new generation of suite tablet anti-theft device, continuing the "simple and easy to use" design style, perfectly display the all categories product, modular design, providing a full range of display anti - theft services for merchandise, customizable display brackets for various commodities.

## Features

- Stylish but streamlined design for suite tablet ;
- Telescopic cable: cable with 60~80" pull lenth, Simplified aftersales enabled, longer cables adapt to more scene requirements;
- Multiple security level choices: Standard & enhanced protection;
- Standard cable with tensile resistance 10kgf;
- Alarm-on-merchandise with 90 dB alarm;
- Quick release sensor with Eastops anti theft screwdriver;
- Charging anti-theft separation solution, lower false alarm probability;
- Use the original PC adapter

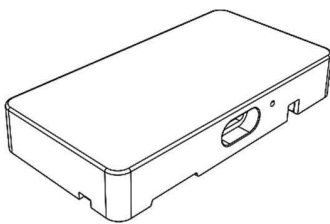

Host

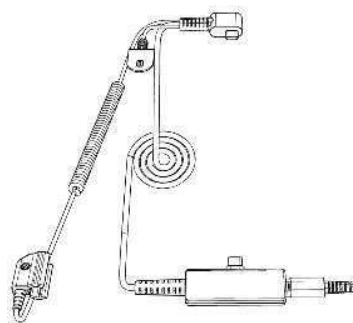

Standard cable

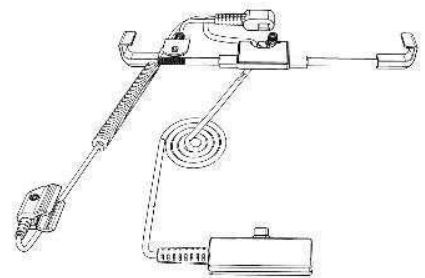

Enhanced cable